



iW Blast TR

Industry-standard theatrical and rental LED wash fixture with intelligent white light

iW Blast TR

Industry-standard theatrical and rental LED wash fixture with intelligent white light

iW Blast TR is a rugged, intelligent white LED fixture designed specifically to withstand taxing stage, set, and touring environments. This rental-friendly fixture offers ease of installation and control, along with the ability to produce high-quality white light with a temperature range of 2700 K to 6500 K. It features a standard 4-pin XLR connector, an innovative elastomeric sleeve that protects the fixture during rough handling, and a pivoting bezel for easy exchange of lenses. An industrial-grade hinge affords quick and reliable fixture aiming and locking. The mounting base easily accommodates truss clamps and other mounting and positioning options. Designed with live entertainment in mind, iW Blast TR is the ideal intelligent white LED fixture for demanding temporary and touring environments.

- Wide range of color temperature and brightness — Channels of warm white and cool white LEDs produce color temperatures ranging from 2700 K to 6500 K. You can adjust fixture brightness while varying or maintaining constant color temperature.
- Pivoting bezel and exchangeable lenses — The pivoting bezel and included 23° soft-focus and 10° clear tempered glass spread lenses let you switch quickly between soft-edge wash lighting and extended beam projection.
- Quick fixture aiming and locking — An industrial-grade constant torque hinge offers stable, 110° fixture tilting for quick and dependable aiming. Standard set screws lock the fixture in position without special tools.
- Versatile mounting options — The pre-assembled mounting base offers a range of options for mounting on the floor or various stage truss clamps. An integral safety bracket lets you easily attach a safety tether.
- On-board temperature monitoring — A compensation circuit prevents damage to the fixture if operating temperatures rise to unsafe levels. An auto-cycling feature automatically restores normal operation after 30 minutes.



Photography: Tom Boner

Rustic Kitchen Bistro & Bar, in Wilkes-Barre, PA, shown above and on the cover, films weekly cooking shows from its in-house restaurant studio. Twelve iW Blast TR fixtures, suspended above the kitchen on a semicircular truss, illuminate the on-air host and guests with a precise shade of uniform white light. During filming, the color temperature can be adjusted on the fly to white-balance the high-definition cameras, rendering colors on-screen exactly as they appear in person. iW Blast TR lets studio chefs and patrons throughout the restaurant take advantage of high-quality white light without the heat and power consumption of conventional light sources.

- Industry-standard power and control — iW Blast TR works seamlessly with the full range of Philips DMX controllers, such as iPlayer 3, ColorDial Pro, or any third-party DMX controller. City Theatrical Inc. offers a complete line of power / data supplies specifically designed for use with iW Blast TR fixtures.



Innovative Protective Sleeve

Because stage and set environments can take their toll on equipment, iW Blast TR features an innovative elastomeric sleeve to protect the fixture and lens from the rigors of multiple setups and teardowns.

Photometrics

Photometric data is based on test results from an independent NIST traceable testing lab. IES data is available at www.philipscolorkinetics.com/support/ies.

iW Blast TR 23° frosted lens

Lumens	1469
Efficacy	29.4 lm / W

Polar Candela Distribution

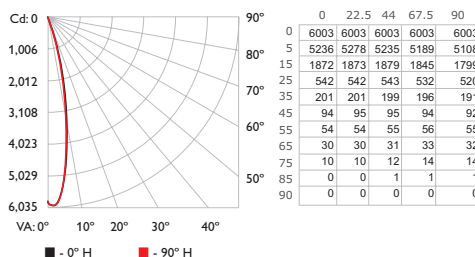

Illuminance at Distance

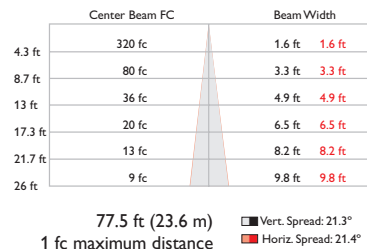

Zonal Lumen

Zone	Lumens	% Lamp	% Luminaire
0-30	1,177.1	80.1%	80.1%
0-40	1,302.0	88.6%	88.6%
0-60	1,423.5	96.9%	96.9%
60-90	45.3	3.1%	3.1%
0-90	1,468.8	100%	100%
90-180	0	0%	0%
0-180	1,468.8	100%	100%

Total Efficiency: 100%

Coefficients Of Utilization - Zonal Cavity Method

Effective Floor Cavity Reflectance: 20%

RCC %:	80		70		50		30		10		0				
RW %:	70	50	30	0	70	50	30	0	50	30	20	50	30	20	0
RCC: 0	1.19	1.11	1.09	1.07	1.16	1.16	1.16	1.00	1.11	1.11	1.11	1.06	1.06	1.06	1.02
RCC: 1	1.14	1.11	1.09	1.07	1.11	1.09	1.07	0.95	1.05	1.04	1.02	1.01	1.00	0.99	0.98
RCC: 2	1.09	1.04	1.01	0.98	1.07	1.03	0.99	0.90	1.00	0.97	0.94	0.97	0.94	0.92	0.94
RCC: 3	1.04	0.99	0.94	0.90	1.02	0.97	0.93	0.85	0.95	0.91	0.88	0.92	0.89	0.87	0.90
RCC: 4	1.00	0.93	0.88	0.85	0.98	0.92	0.88	0.81	0.90	0.86	0.83	0.88	0.85	0.82	0.86
RCC: 5	0.96	0.89	0.84	0.80	0.95	0.88	0.83	0.77	0.86	0.82	0.79	0.85	0.81	0.78	0.83
RCC: 6	0.93	0.85	0.80	0.76	0.91	0.84	0.79	0.74	0.83	0.78	0.75	0.81	0.78	0.75	0.80
RCC: 7	0.89	0.81	0.76	0.73	0.88	0.81	0.76	0.71	0.79	0.75	0.72	0.78	0.75	0.72	0.77
RCC: 8	0.86	0.78	0.73	0.70	0.85	0.78	0.73	0.68	0.77	0.72	0.69	0.76	0.72	0.69	0.75
RCC: 9	0.83	0.75	0.70	0.67	0.82	0.75	0.70	0.66	0.74	0.70	0.67	0.73	0.69	0.66	0.72
RCC: 10	0.81	0.73	0.68	0.65	0.80	0.72	0.68	0.64	0.71	0.67	0.64	0.71	0.67	0.64	0.70

RCC %: Ceiling reflectance percentage, RW %: Wall reflectance percentage, RCR: Room cavity ratio

iW Blast TR 10° clear lens

Lumens	1679
Efficacy	33.6 lm / W

Polar Candela Distribution

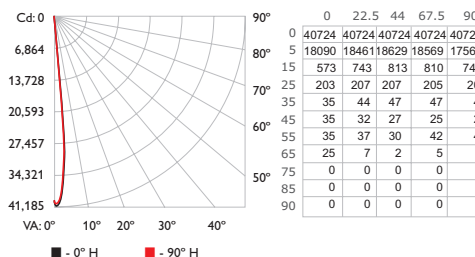

Illuminance at Distance

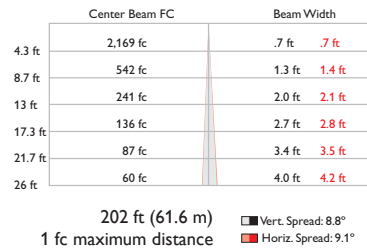

Zonal Lumen

Zone	Lumens	% Lamp	% Luminaire
0-30	1,590.5	94.7%	94.7%
0-40	1,623.5	96.7%	96.7%
0-60	1,674.1	99.7%	99.7%
60-90	5.2	0.3%	0.3%
0-90	1,679.3	100%	100%
90-180	0	0%	0%
0-180	1,679.3	100%	100%

Total Efficiency: 100%

Coefficients Of Utilization - Zonal Cavity Method

Effective Floor Cavity Reflectance: 20%

RCC %:	80		70		50		30		10		0				
RW %:	70	50	30	0	70	50	30	0	50	30	20	50	30	20	0
RCC: 0	1.19	1.19	1.19	1.19	1.16	1.16	1.16	1.00	1.11	1.11	1.11	1.06	1.06	1.06	1.02
RCC: 1	1.16	1.14	1.12	1.11	1.13	1.12	1.10	0.98	1.08	1.07	1.06	1.04	1.03	1.03	1.01
RCC: 2	1.13	1.10	1.07	1.05	1.11	1.08	1.06	0.97	1.05	1.03	1.02	1.02	1.01	1.00	0.99
RCC: 3	1.10	1.06	1.03	1.01	1.08	1.05	1.02	0.95	1.03	1.00	0.99	1.00	0.97	0.98	0.97
RCC: 4	1.08	1.03	1.00	0.98	1.06	1.02	0.99	0.94	1.00	0.98	0.96	0.99	0.97	0.95	0.97
RCC: 5	1.06	1.01	0.98	0.95	1.04	1.00	0.97	0.92	0.99	0.96	0.94	0.97	0.95	0.93	0.96
RCC: 6	1.04	0.99	0.95	0.93	1.03	0.98	0.95	0.91	0.97	0.94	0.92	0.96	0.93	0.92	0.95
RCC: 7	1.02	0.97	0.94	0.91	1.01	0.96	0.93	0.90	0.95	0.93	0.91	0.94	0.92	0.90	0.94
RCC: 8	1.00	0.95	0.92	0.90	0.99	0.95	0.92	0.89	0.94	0.91	0.90	0.93	0.91	0.89	0.92
RCC: 9	0.99	0.94	0.91	0.89	0.98	0.93	0.91	0.88	0.93	0.90	0.88	0.92	0.90	0.88	0.91
RCC: 10	0.97	0.93	0.90	0.88	0.97	0.92	0.89	0.87	0.92	0.89	0.87	0.91	0.89	0.87	0.91

RCC %: Ceiling reflectance percentage, RW %: Wall reflectance percentage, RCR: Room cavity ratio

For lux multiply fc by 10.7

Specifications

Due to continuous improvements and innovations, specifications may change without notice.

Item	Specification	Details
Output	Beam Angle	23° / 10°
	Lumens*	1469 (23° beam angle) 1679 (10° beam angle)
	Color Temperature†	2700 K – 6500 K
	Efficacy (lm / W)	29.4 (23° beam angle) 33.6 (10° beam angle)
	Mixing Distance	6 in (152 mm) to uniform light
	CRI	83 all, 83 warm, 74 cool
	Lumen Maintenance‡	70,000 hours L70 @ 25° C (typical application)
Electrical	Input Voltage	24 VDC via PDS-750 TRX, PDS-375 TRX, PDS-150e, or PDS-60
	Power Consumption	50 W maximum at full output, steady state
Control	Interface	DMX via power / data supply
	Control System	Philips full range of controllers, including Light System Manager, iPlayer 3, or any third-party DMX controllers
Physical	Dimensions (Height x Width x Depth)	8 x 13.5 x 2.6 in (203 x 343 x 66 mm)
	Weight	6.4 lb (2.9 kg)
	Housing	Die-cast aluminium, black powder-coated finish
	Lens	Frosted glass (23° beam angle) Clear glass (10° beam angle)
	Fixture Connections	6 ft (1.8 m) power / data cable with 4-pin XLR connector
	Temperature Ranges	-40° – 122° F (-40° – 50° C) Operating -4° – 122° F (-20° – 50° C) Startup -40° – 176° F (-40° – 80° C) Storage
	Humidity	0 – 95%, non-condensing
Certification and Safety	Maximum Cable Length	Up to 54 ft (16.5 m) extension for total of 60 ft (18.3 m) maximum
	Certification	UL / cUL, FCC Class B, CE, CCC, C-Tick
	Environment	Dry Location, IP20

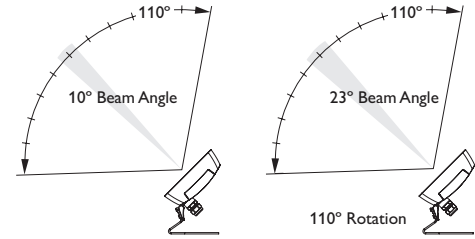

In addition to the PDS-750 TRX power / data supply, City Theatrical Inc. offers a line of power / data supplies specifically designed for Blast TR fixtures. Visit www.citytheatrical.com for details.

City Theatrical Inc. offers a line of polycarbonate holographic lenses for iW Blast TR, with a range of symmetric and asymmetric beam angles. Visit www.citytheatrical.com for details.

* Lumen measurement complies with IES LM-79-08 testing procedures.

† Color temperatures conform to nominal CCTs as defined in ANSI Chromaticity Standard C78.377A.

‡ L70 = 70% lumen maintenance (when light output drops below 70% of initial output). Ambient luminaire temperatures specified. Lumen maintenance calculations are based on lifetime prediction graphs supplied by LED source manufacturers. Calculations for white-light LED fixtures are based on measurements that comply with IES LM-80-08 testing procedures. Refer to www.philipscolorkinetics.com/support/appnotes/lm-80-08.pdf for more information.



CHROMACORE[®] | OPTIBIN[®]
CK TECHNOLOGY | CK TECHNOLOGY

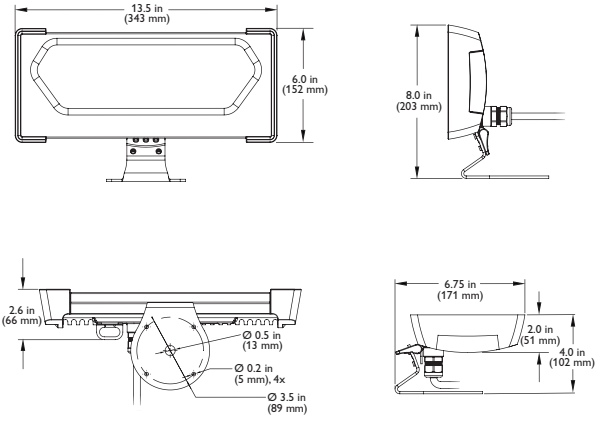

Fixtures and Data / Power Supplies

iW Blast TR fixtures are part of a complete low-voltage system which includes one or more power / data supplies and any third-party DMX controller.

Item	Item Number	Philips 12NC
iW Blast TR	501-000001-00	910503700183
Protective Sleeve	120-000062-00	910503700370
Mounting Base	120-000060-00	910503700369
Lenses (23° frosted glass and 10° clear glass)	120-000066-00	910503700367
PDS-375 TRX	109-000030-01	910503702284
PDS-750 TRX	109-000030-00	910503702319

Replacement parts

Included in the box

iW Blast TR fixture with 6 ft (1.8 m) leader cable
Frosted glass 23° lens
Clear glass 10° lens
Protective elastomeric sleeve
3/16 in hex key wrench
Installation Instructions

* You must remove the fixture's protective sleeve before you can attach the accessory holder. Reinstall the protective sleeve after use.

Accessories

Designed specifically for the family of Blast fixtures, accessories provide additional options for controlling and dispersing light. Accessory holders screw to the side of the fixture and are required for mounting accessories. Accessory holders prevent accessories from falling out if the fixture is tipped or hung upside down.

Item	Type	Item Number	Philips 12NC	
	Accessory Holders	Black	120-000003-04	910503702840
	Half Top Hats	Black	120-000009-04	910503702848
	Top Hats	Black	120-000005-04	910503702844
	Egg Crate Louvers	Black	120-000015-04	910503702852
	Barndoors	Black	120-000019-04	910503702856
	Horizontal Glass Spread Lens*	36° (ribs out) / 50° (ribs in)	120-000025-00	910503703897
	Horizontal / Vertical Glass Spread Lens*	40°	120-000025-01	910503703898

* Intended for use with Blast fixtures with 10° clear lens

Use Item Number when ordering in North America.

Installation

iW Blast TR fixtures are designed for easy setup, configuration, and teardown. You can connect iW Blast TR fixtures directly to a power / data supply, such as the PDS-750 TRX, using the built-in 6 ft (1.8 m) power cable with standard XLR connector.

Owner / User Responsibilities

It is the responsibility of the contractor, installer, purchaser, owner, and user to install, maintain, and operate iW Blast TR fixtures in such a manner as to comply with all applicable codes, state and local laws, ordinances, and regulations. Consult with the appropriate electrical inspector to ensure compliance.

 Refer to the iW Blast TR Installation Instructions for specific warning and caution statements.

Create a Lighting Design Plan

1. Determine the appropriate location of each power / data supply in relation to the light fixtures, and of the light fixtures in relation to each other.

iW Blast TR connects to the power / data supply over a built-in 6 ft (1.8 m) leader cable with a standard 4-pin XLR male connector. The leader cable can be extended with a standard XLR male to XLR female patch cable, up to a maximum overall length of 60 ft (18 m).

The number of iW Blast TR fixtures that each power / data supply can support is determined by such factors as the supply's capacity and number of available ports, line voltage, circuit load, voltage drop, and leader cable lengths. The PDS-750 TRX, for example, can support up to 12 iW Blast TR fixtures, each with a leader cable of up to 60 ft (18 m).

2. On an architectural diagram or other diagram that shows the physical layout of the installation, identify the locations of all switches, controllers, power / data supplied, fixtures, and cables.

Leader Cable connector dimensions

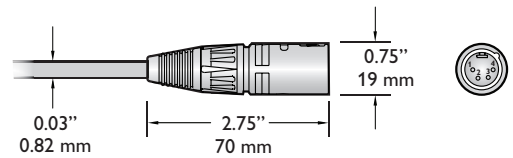

Start the Installation

1. Install all power / data supplies, including any interfaces with controllers. Power / data supplies and external controllers send power and control signals to the fixtures over the fixture's leader cable.
2. Verify that all additional supporting equipment (switches, controllers) is in place.
3. Ensure that all additional parts and tools are available, including:
 - The included 3/16 in hex key wrench for locking the fixtures in position
 - A Phillips head screwdriver for removing the bezel screws
 - C-clamps or bases for pipe, truss, or floor mounting, as required

Leader cable pinouts

Pin	Signal	Wire Color
1	+24VDC	Red
2	(not used)	
3	Data	White
4	DC Common	Black

Install the Fixtures

Make sure the power is OFF before mounting and connecting iW Blast TR fixtures.

1. The mounting base of each iW Blast TR fixture provides a clearance hole for a 1/2 in bolt for mounting to a pipe, truss, weighted base, or floor using a standard theatrical C-clamp or other mounting hardware. When mounting iW Blast TR, ensure that the installation is suitable and safe and that the hardware is properly rated for the task.

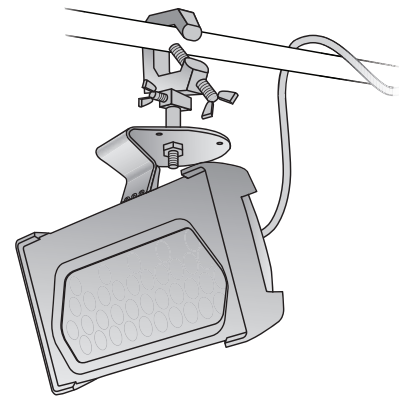

* For complete instructions on how to wire the PDS-750 TRX, refer to the PDS-750 TRX User's Manual.

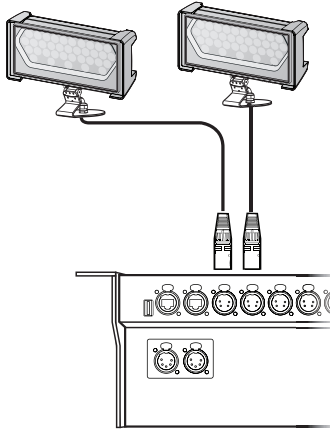

* To ease removal and replacement of the protective cover, run the fixture at full power until the heat from the fixture housing softens the cover material.

2. When mounting iW Blast TR fixtures on the floor or a base, ensure that the fixture sits flush to the surface and use mounting hardware suitable for the mounting surface.
3. Connect each iW Blast TR fixture to an available female 4-pin output on the power / data supply, iW Blast TR fixtures are provided with a permanently connected 6 ft (1.8 m) cable. The leader cable can be extended with a standard XLR male to XLR female patch cable, up to a maximum overall length of 60 ft (18 m).

Exchanging iW Blast TR Lenses

iW Blast TR is designed to let you quickly and easily exchange lenses. The clear 10° lens is designed for long throw and spotlighting applications, while the frosted 23° lens is designed for wash lighting applications. The 23° lens is factory installed, and the 10° lens is included in the box.

1. Remove the protective cover from the fixture.
2. Using a Phillips head screwdriver, remove the two lock-down screws located on each side of the fixture at the top of the bezel. (Do not remove the pivot screws on the edge of the bezel closest to the base.)
3. Using the tabs on the bezel, pivot the bezel forward to access the lens.
4. Remove the installed lens.
5. Clean both sides of the lens using a mild, non-abrasive cleaner. Handle the lens by the gasket, making sure not to touch or soil either surface. Place the lens in the fixture housing, making sure the gasket around the lens is properly fitted. Install the frosted 23° glass lens smooth side up.
6. Close the bezel, tighten the lock-down screws, and replace the protective cover.

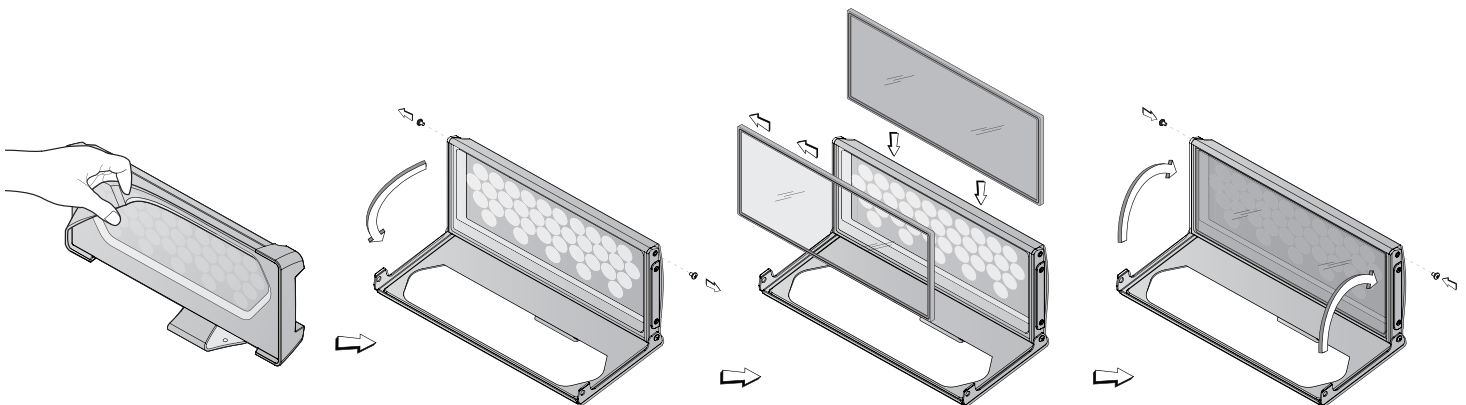

Attach Safety Cable (Optional)

Each iW Blast TR fixture is designed for use with a safety cable to tether it to a secure anchor point. When dictated by local or state code or advised by a structural engineer, attach a safety cable to the bracket on the back of the fixture using a standard carabiner clip. Attach the safety cable to the mounting surface using a method that follows the code or engineer's requirements.

Address and Configuring

For installations in which you want to change the brightness and color temperature of all fixtures in unison, no fixture addressing or configuration is necessary.

To support dynamic effects that automatically modify brightness and color temperature on individual fixtures, you must address and configure iW Blast TR Powercore fixtures as you would any color-changing (RGB) fixture.

iW Blast TR Powercore fixtures use DMX addresses to communicate with controllers. The number of DMX addresses each iW Blast TR Powercore fixture requires depends on the fixture's configuration.

iW Blast TR Powercore fixtures operate in 8-bit mode by default. You can configure fixtures to operate in 16-bit mode, which increases resolution for smoother dimming and more precise control. In 8-bit mode, fixtures use one DMX address per LED channel. In 16-bit mode, fixtures use two DMX addresses per LED channel. The first DMX address corresponds to the "coarse" data for that channel, and the second corresponds to the "fine" data. By using double the number of DMX addresses, 16-bit mode increases fixture resolution from 256 dimming steps to 65,536 (256 x 256) dimming steps.

You can address and configure iW Blast TR Powercore fixtures in much the same way as you would address any RGB fixture. The red channel corresponds to the warm LEDs, the green channel corresponds to the cool LEDs, and the blue channel is not used. Note that although the blue DMX channel is not used, it is *assigned*, so that each iW Blast TR Powercore fixture uses three sequential DMX addresses (or a multiple of three addresses).

iW Blast TR Powercore fixtures come factory-addressed with a starting DMX address of 1. For lighting designs where fixtures work in unison, all fixtures can be assigned the same starting DMX address. Changes to the default starting DMX addresses are not necessary, but if lights were previously readdressed for use in other installations, you must reset them. For light show designs that show different light output on different fixtures simultaneously, you must assign unique DMX addresses to your fixtures and sort them in a useful order.

The following table shows the DMX channel assignments for 8-bit and 16-bit iW Blast TR Powercore configurations, assuming a starting DMX address of 1.

DMX Channel Assignments

8-bit Mode	1		2		3	
	Warm		Cool		Unused	
16-Bit Mode	1	2	3	4	5	6
	Warm	Warm	Cool	Cool	Unused	Unused

Safety cable bracket location on fixture

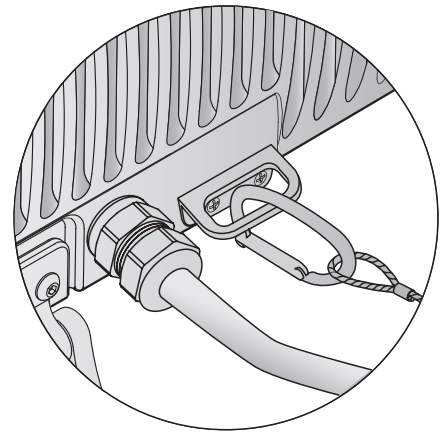

Safety cable minimum requirements

Material	316 Stainless Steel
Size	5/64 to 3/16 in (2 to 5 mm) nominal diameter. Minimum break load must be greater than 400 lbs (181 kg)
Construction	7 x 7 (49 wires) preformed stranded

* If necessary, you can individually address iW Blast TR fixtures using QuickPlay Pro and SmartJack Pro. You can download QuickPlay Pro and the Addressing and Configuration Guide from www.philipscolorkinetics.com/support/addressing/

LED Channels

RGB	iW Blast TR Powercore
Red	Warm
Green	Cool
Blue	Unused

Aim and Lock the Fixtures

Make sure the power is ON before aiming and locking iW Blast TR fixtures.

* Do not look directly into the fixture when aiming and locking.

Using the provided hex key wrench, loosen the tilting set screws located on the front of the fixture's mounting base. Aim the fixture by tilting the beam as desired. Tighten the set screws to lock the fixture in place.

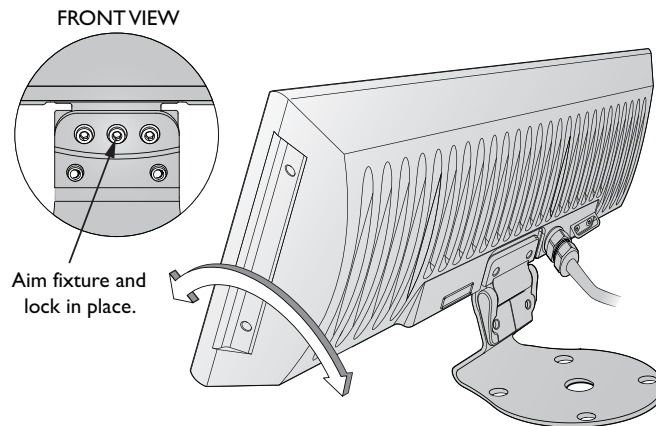



Philips Color Kinetics
3 Burlington Woods Drive
Burlington, Massachusetts 01803 USA
Tel 888.385.5742
Tel 617.423.9999
Fax 617.423.9998
www.philipscolorkinetics.com

Copyright © 2010 – 2012 Philips Solid-State Lighting Solutions, Inc. All rights reserved.
Chromacore, Chromasic, CK, the CK logo, Color Kinetics, the Color Kinetics logo, ColorBlast,
ColorBlaze, ColorBurst, eW Fuse, ColorGraze, ColorPlay, ColorReach, iW Reach, eW Reach,
DIMand, EssentialWhite, eW, iColor, iColor Cove, IntelliWhite, iW, iPlayer, Optibin, and Powercore
are either registered trademarks or trademarks of Philips Solid-State Lighting Solutions, Inc. in
the United States and / or other countries. All other brand or product names are trademarks
or registered trademarks of their respective owners. Due to continuous improvements and
innovations, specifications may change without notice.
Cover Photo: Tom Bomer: Rustic Kitchen, Mohegan Sun
at Pocono Downs, Wilkes-Barre, Pennsylvania

DAS-000012-00 R03 05-12