



eW Blast Powercore

The world's leading exterior LED wash fixture with solid white light



eW Blast Powercore

The world's leading exterior LED wash fixture with intelligent white light

eW Blast Powercore is an LED lighting fixture providing a high-intensity wash of white light while consuming less energy than comparable non-LED light fixtures. Rated for outdoor use, eW Blast Powercore offers the efficiency and cost-effectiveness of Powercore technology in a rugged die-cast aluminum housing. eW Blast Powercore is ideal for applications as diverse as highlighting architectural features, general site illumination, and lighting signage and retail spaces.

- Integrates patented Powercore technology — Powercore technology rapidly, efficiently, and accurately controls power output to eW Blast Powercore fixtures directly from line voltage, supporting long fixture runs and eliminating the need for external power supplies. Contractor-friendly installation using standard mounting and wiring dramatically simplifies installation and helps lower total system cost.
- Supports new applications for white light — With long useful source life (up to 70,000 hours at 70% lumen maintenance), eW Blast Powercore can significantly reduce or eliminate maintenance problems, allowing the use of white lighting in spaces where lamp maintenance may be impossible. For example, you can effectively illuminate building features from positions accessible only by crane.
- High-intensity, energy-efficient white light — With an output of up to 2390 lumens, eW Blast Powercore offers high-intensity illumination at a significantly lower power draw than comparable non-LED fixtures.
- Versatile lighting options — eW Blast Powercore is available in four beam angles: 21° and 36° for soft edges, 83° with no optic for uniformly washing façades, and 10° for extended light projection. Rugged die-cast aluminum housing is available in white or black.
- Flexible light positioning — Fixtures can be mounted to a junction box on a wall, ceiling, or floor for maximum flexibility. Locking base swivel offers friction-free rotation of up to 350°, and 110° fixture tilting provides quick fixture positioning without special tools.
- Support for multiple voltages — eW Blast Powercore accepts power input of 100, 120, 240, and 277 VAC, allowing installation and operation from line voltage in a variety of locations.
- Dimming capability — Patented DIMand technology offers smooth dimming capability with selected commercially available reverse-phase ELV-type dimmers.



Outdoor Rated

Fully sealed for maximum fixture life, eW Blast Powercore fixtures meet or exceed specifications for use in wet locations.

The Arrival of White LED Lighting for General Illumination

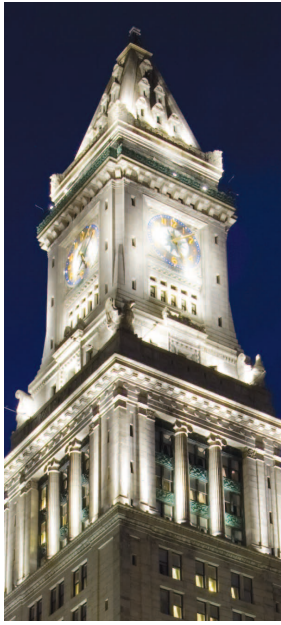

Photography: John Brandon Miller Photography

Retrofitting Boston's Marriott Custom House Tower

In 2008, Boston's first official skyscraper, the Marriott Custom House Tower, shown here and on the cover, underwent a long-awaited lighting redesign that restores its prominence on the Boston skyline in a smart and sustainable way. Formerly lit by incandescent-based fixtures that had fallen into disrepair, the tower was restored using energy-efficient, low-maintenance white LED fixtures from Philips. A combination of 125 eW Blast Powercore and eW Graze Powercore fixtures now fully illuminate the tower from the 17th floor to the peak.

Cost-Effective, Energy-Efficient, and Easy to Maintain

Not only do the LED fixtures in the installation consume just one third the energy of the previous incandescent sources, the LED sources that they use have a projected useful life of more than 20 years at six hours of use per day, requiring far less maintenance.



Lighting Design: Lam Partners
Photography: Brad Koerner

By incorporating Powercore technology to directly accept line voltage, the fixtures eliminate the special cabling and external low-voltage power supplies that other LED lighting fixtures require. Because they use standard wiring and power sources, the lighting designers were able to easily replace the former incandescent light fixtures one-for-one in their existing locations and mountings.

New Possibilities for White LED Lighting

The efficiency and long source life of eW Blast Powercore and other Philips white LED fixtures open up new possibilities for sustainable architectural lighting. As the Custom House Tower installation shows, in dramatic and elegant fashion, white LED lighting has arrived as a viable, energy-efficient alternative for general illumination.

Photometrics

Photometric data is based on test results from an independent NIST traceable testing lab. IES data is available at www.philipscolorkinetics.com/support/ies.

eW Blast Powercore 2700 K, 10° Clear Lens

Lumens	1990
Efficacy	42.3

Polar Candela Distribution

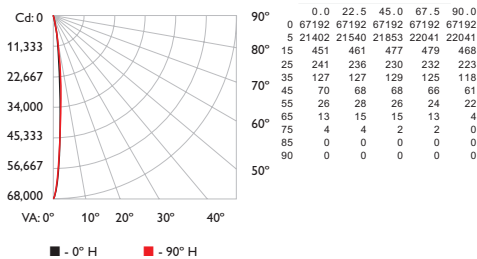

Illuminance at Distance

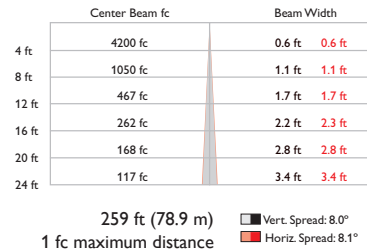

Zonal Lumen

ZONE	LUMENS	%FIXT
0- 30	1819	91.4
0- 40	1900	95.5
0- 60	1974	99.2
0- 90	1990	100.0
90-180	0	0.0
0-180	1990	100.0

Coefficients Of Utilization - Zonal Cavity Method

RC	80				70				50				Effective Floor Cavity Reflectance: 20%			
	70	50	30	10	70	50	30	10	50	30	10	50	30	10	0	
0	119119119119	116116116116	1111111111	106106106	102102102	100										
1	116114112111	113112110109	108107106	104103103	101100100	98										
2	113110107105	111108106104	105103102	102101100	100	98	96									
3	110106103101	108105102100	103100	99	100	99	97	98	97	96	94					
4	108103100	98	106102	99	97	100	98	96	99	97	95	97	95	94	93	
5	106101	98	95	104100	97	95	99	96	94	97	95	93	96	94	93	
6	104	99	96	103	98	95	93	97	94	92	96	94	92	95	93	
7	102	97	94	101	97	94	91	96	93	91	95	92	91	94	92	
8	100	96	92	100	95	92	90	94	92	90	94	91	90	93	91	
9	99	94	91	98	94	91	89	93	91	89	93	90	89	92	90	
10	98	93	90	97	93	90	88	92	90	88	92	89	88	91	89	

RCC %: Ceiling reflectance percentage, RW %: Wall reflectance percentage, RCR: Room cavity ratio

eW Blast Powercore 2700 K, 21° Frosted Lens

Lumens	1786
Efficacy	38.2

Polar Candela Distribution

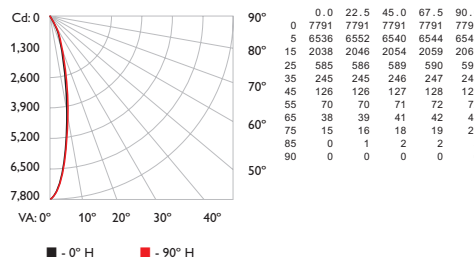

Illuminance at Distance

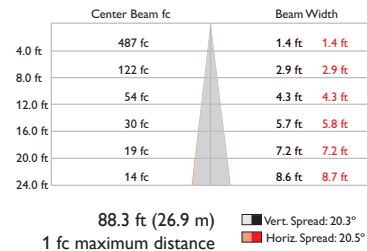

Zonal Lumen

ZONE	LUMENS	%FIXT
0- 30	1403	78.6
0- 40	1560	87.4
0- 60	1724	96.5
0- 90	1786	100.0
90-180	0	0.0
0-180	1786	100.0

Coefficients Of Utilization - Zonal Cavity Method

RC	80				70				50				Effective Floor Cavity Reflectance: 20%			
	70	50	30	10	70	50	30	10	50	30	10	50	30	10	0	
0	119119119119	116116116116	1111111111	106106106	102102102	100										
1	114111109107	111109107105	105103102	101100	99	98	97	96	94							
2	109104100	97	107103	99	96	99	97	94	96	94	92	94	92	90	89	
3	104	98	94	102	97	93	89	94	91	88	92	89	87	85	84	
4	100	93	88	98	92	87	84	90	86	83	88	85	82	86	83	
5	96	88	83	94	88	83	79	86	82	79	84	81	78	83	80	
6	92	84	79	91	84	79	75	82	78	75	81	77	74	80	76	
7	89	81	76	88	80	75	72	79	75	72	78	74	71	77	74	
8	86	78	73	85	77	72	69	76	72	69	75	71	69	74	71	
9	83	75	70	82	74	70	67	74	69	66	73	69	66	72	68	
10	80	72	68	80	72	67	64	71	67	64	71	67	64	70	66	

RCC %: Ceiling reflectance percentage, RW %: Wall reflectance percentage, RCR: Room cavity ratio

For lux multiply fc by 10.7

eW Blast Powercore 2700 K, 36° Frosted Lens

Lumens	1613
Efficacy	32.5

Polar Candela Distribution

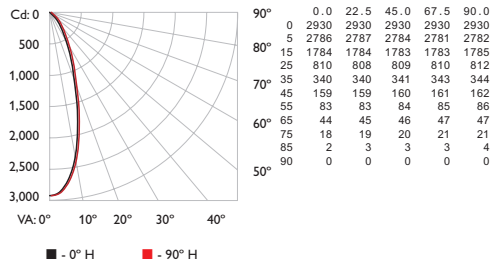

Illuminance at Distance

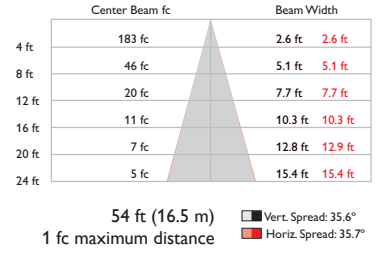

Zonal Lumen

ZONE	LUMENS	%FIXT
0- 30	1119	69.4
0- 40	1339	83.0
0- 60	1542	95.6
0- 90	1613	100.0
90-180	0	0.0
0-180	1613	100.0

Coefficients Of Utilization - Zonal Cavity Method

		Effective Floor Cavity Reflectance: 20%														
		80			70			50			30			10		
RC	RW	70	50	30	10	70	50	30	10	50	30	10	50	30	10	
0	119119119119	116116116116	1111111111	106106106	102102102	100										
1	113110107105	111108105103	104102100	100	99	97	97	95	94	92						
2	107102	98	94	105100	96	93	97	94	91	94	91	89	91	89	87	
3	101	95	89	85	99	93	88	85	91	86	83	88	85	82	86	
4	96	88	83	78	94	87	82	78	85	80	77	83	79	76	81	
5	91	83	77	72	90	82	76	72	80	75	71	78	74	71	77	
6	87	78	72	67	86	77	71	67	76	71	67	74	70	66	73	
7	83	74	68	63	82	73	67	63	72	67	63	70	66	62	69	
8	79	70	64	60	78	69	63	59	68	63	59	67	62	59	66	
9	76	66	60	56	75	66	60	56	65	60	56	64	59	56	63	
10	73	63	57	54	72	63	57	53	62	57	53	61	56	53	60	

RCC %: Ceiling reflectance percentage, RW %: Wall reflectance percentage, RCR: Room cavity ratio

eW Blast Powercore 2700 K, 83° No Optic

Lumens	1969
Efficacy	40.2

Polar Candela Distribution

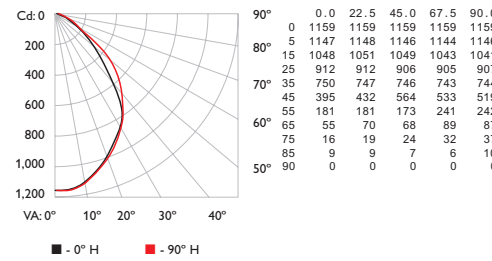

Illuminance at Distance

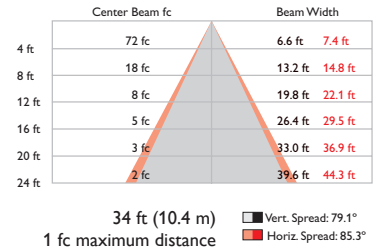

Zonal Lumen

ZONE	LUMENS	%FIXT
0- 30	820	41.7
0- 40	1284	65.2
0- 60	1855	94.2
0- 90	1969	100.0
90-180	0	0.0
0-180	1969	100.0

Coefficients Of Utilization - Zonal Cavity Method

		Effective Floor Cavity Reflectance: 20%														
		80			70			50			30			10		
RC	RW	70	50	30	10	70	50	30	10	50	30	10	50	30	10	
0	119119119119	116116116116	1111111111	106106106	102102102	100										
1	112108105102	109106103100	102	99	97	98	96	94	94	93	91	89				
2	104	97	92	88	101	96	91	87	92	88	85	89	86	83	86	
3	97	88	82	76	94	87	81	76	84	79	74	81	77	73	79	
4	90	80	73	67	88	79	72	67	76	71	66	74	69	65	72	
5	84	73	65	60	82	72	65	59	70	64	59	68	63	58	66	
6	78	67	59	53	76	66	59	53	64	58	53	62	57	52	61	
7	73	61	54	48	71	60	53	48	59	52	48	58	52	47	56	
8	68	56	49	44	67	56	49	44	55	48	43	53	47	43	52	
9	64	52	45	40	63	52	45	40	51	44	40	50	44	40	49	
10	60	49	41	37	59	48	41	37	47	41	36	46	40	36	45	

RCC %: Ceiling reflectance percentage, RW %: Wall reflectance percentage, RCR: Room cavity ratio

For lux multiply fc by 10.7

eW Blast Powercore 4000 K, 10° Clear Lens

Lumens	2390
Efficacy	45.9

Polar Candela Distribution

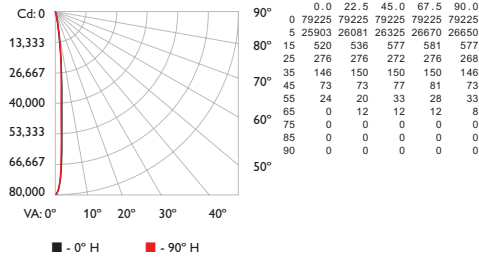

Illuminance at Distance

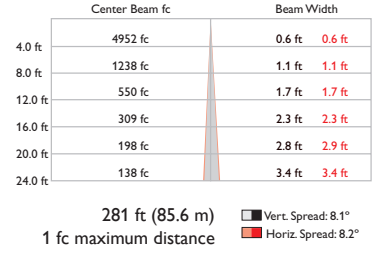

Zonal Lumen

ZONE	LUMENS	%FIXT
0- 30	2200	92.0
0- 40	2297	96.1
0- 60	2380	99.6
0- 90	2390	100.0
90-180	0	0.0
0-180	2390	100.0

Coefficients Of Utilization - Zonal Cavity Method

RC	80	70	50	30	10	0
RW	70 50 30 10	70 50 30 10	50 30 10	50 30 10	50 30 10	0
0	119119119119	116116116116	1111111111	106106106	102102102	100
1	116114112111	114112111109	108107106	104104103	101100100	98
2	113110107105	111108106104	105104102	102101100	100 99 98	97
3	110107104101	109105103101	103101 99	101 99 98	99 97 96	95
4	108104101 98	107103100 98	101 98 97	99 97 96	97 96 95	93
5	106101 98 96	105101 98 95	99 97 95	98 96 94	96 95 93	92
6	104 99 96 94	103 99 96 94	97 95 93	96 94 92	95 93 92	91
7	102 98 94 92	102 97 94 92	96 94 92	95 93 91	94 92 91	90
8	101 96 93 91	100 96 93 91	95 92 91	94 92 90	93 91 90	89
9	100 95 92 90	99 94 92 90	94 91 90	93 91 89	92 90 89	88
10	98 94 91 89	98 93 91 89	93 90 89	92 90 88	92 90 88	88

RCC %: Ceiling reflectance percentage, RW %: Wall reflectance percentage, RCR: Room cavity ratio

eW Blast Powercore 4000 K, 21° Frosted Lens

Lumens	2141
Efficacy	50.9

Polar Candela Distribution

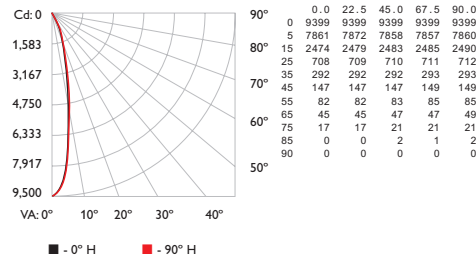

Illuminance at Distance

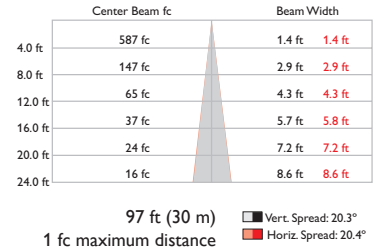

Zonal Lumen

ZONE	LUMENS	%FIXT
0- 30	1692	79.0
0- 40	1880	87.8
0- 60	2071	96.7
0- 90	2141	100.0
90-180	0	0.0
0-180	2141	100.0

Coefficients Of Utilization - Zonal Cavity Method

RC	80	70	50	30	10	0
RW	70 50 30 10	70 50 30 10	50 30 10	50 30 10	50 30 10	0
0	119119119119	116116116116	1111111111	106106106	102102102	100
1	114111109107	111109107105	105103102	101100 99	98 97 96	94
2	109104101 98	107103 99 96	99 97 94	97 94 92	94 92 90	89
3	104 98 94 90	102 97 93 90	94 91 88	92 89 87	90 88 86	84
4	100 93 88 85	98 92 88 84	90 86 83	88 85 82	86 84 81	80
5	96 89 84 80	95 88 83 80	86 82 79	85 81 78	83 80 77	76
6	92 85 80 76	91 84 79 76	83 78 75	81 78 75	80 77 74	73
7	89 81 76 73	88 81 76 72	79 75 72	78 74 72	77 74 71	70
8	86 78 73 70	85 78 73 69	77 72 69	76 72 69	75 71 69	67
9	83 75 70 67	82 75 70 67	74 70 67	73 69 66	72 69 66	65
10	81 73 68 65	80 72 68 65	71 67 64	71 67 64	70 67 64	63

RCC %: Ceiling reflectance percentage, RW %: Wall reflectance percentage, RCR: Room cavity ratio

For lux multiply fc by 10.7

eW Blast Powercore 4000 K, 36° Frosted Lens

Lumens	1868
Efficacy	41.9

Polar Candela Distribution

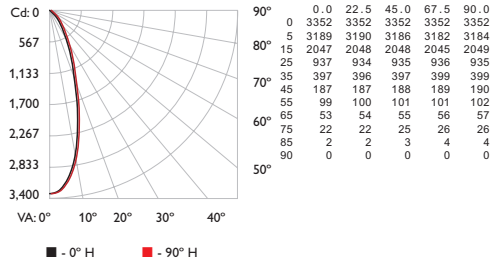

Illuminance at Distance

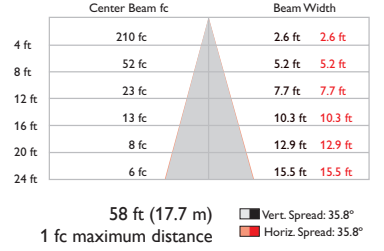

Zonal Lumen

ZONE	LUMENS	%FIXT
0- 30	1287	68.9
0- 40	1542	82.6
0- 60	1782	95.4
0- 90	1868	100.0
90-180	0	0.0
0-180	1868	100.0

Coefficients Of Utilization - Zonal Cavity Method

Effective Floor Cavity Reflectance: 20%

RC	80	70	50	30	10	0					
RW	70	50	30	10	50	30	10	50	30	10	0
0	119119119119	116116116116	111111111111	106106106	102102102	100					
1	113110107105	110108105103	104102100	100 98 97	97 95 94	92					
2	107102 97 94	105100 96 93	97 93 91	94 91 89	91 89 87	85					
3	101 94 89 85	99 93 88 84	90 86 83	88 84 82	86 83 80	79					
4	96 88 82 78	94 87 82 77	85 80 77	83 79 76	81 78 75	73					
5	91 83 77 72	90 82 76 72	80 75 71	78 74 70	77 73 70	68					
6	87 78 72 67	85 77 71 67	75 70 66	74 69 66	73 69 66	64					
7	83 73 67 63	81 73 67 63	71 66 62	70 66 62	69 65 62	60					
8	79 69 63 59	78 69 63 59	68 63 59	67 62 59	66 62 58	57					
9	76 66 60 56	74 65 60 56	65 59 56	64 59 56	63 59 55	54					
10	72 63 57 53	71 62 57 53	62 56 53	61 56 53	60 56 53	51					

RCC %: Ceiling reflectance percentage, RW %: Wall reflectance percentage, RCR: Room cavity ratio

eW Blast Powercore 4000 K, 83° No Optic

Lumens	2398
Efficacy	49.2

Polar Candela Distribution

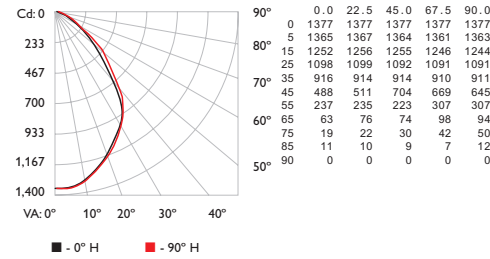

Illuminance at Distance

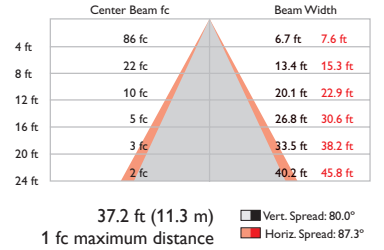

Zonal Lumen

ZONE	LUMENS	%FIXT
0- 30	984	41.0
0- 40	1552	64.7
0- 60	2267	94.5
0- 90	2398	100.0
90-180	0	0.0
0-180	2398	100.0

Coefficients Of Utilization - Zonal Cavity Method

Effective Floor Cavity Reflectance: 20%

RC	80	70	50	30	10	0					
RW	70	50	30	10	50	30	10	50	30	10	0
0	119119119119	116116116116	111111111111	106106106	102102102	100					
1	112108105102	109106103100	102 99 97	98 96 94	94 93 91	89					
2	104 97 92 88	101 96 91 87	92 88 85	89 86 83	86 83 81	79					
3	96 88 81 76	94 87 80 76	84 79 74	81 77 73	79 75 72	70					
4	90 80 73 67	88 79 72 67	76 70 66	74 69 65	72 68 64	62					
5	83 73 65 60	82 72 65 59	70 63 59	68 62 58	66 61 57	56					
6	78 66 59 53	76 66 58 53	64 57 53	62 57 52	61 56 52	50					
7	73 61 53 48	71 60 53 48	59 52 48	57 52 47	56 51 47	45					
8	68 56 49 43	67 55 48 43	54 48 43	53 47 43	52 47 43	41					
9	64 52 45 40	63 51 44 40	50 44 39	49 43 39	48 43 39	37					
10	60 48 41 36	59 48 41 36	47 41 36	46 40 36	45 40 36	34					

RCC %: Ceiling reflectance percentage, RW %: Wall reflectance percentage, RCR: Room cavity ratio

For lux multiply fc by 10.7

eW Blast Powercore Specifications

Due to continuous improvements and innovations, specifications may change without notice.

Item	Color Temperature*	10°	21°	36°	83°
Lumens†	2700 K	1990	1786	1613	1969
	4000 K	2390	2141	1868	2398
Efficacy (lm / W)	2700 K	42.3	38.2	32.5	40.2
	4000 K	45.9	50.9	41.9	49.2
CRI	2700 K	83	83	83	83
	4000 K	82	82	82	82

Item	Specification	2700 K*	4000 K*
Output	Beam Angle	10° / 21° / 36° / 83° (no optic)	
	Mixing Distance	6 in (152 mm) to uniform light	
	Lumen Maintenance‡	70,000 hours L70 @ 25° C 90,000 hours L50 @ 25° C	37,000 hours L70 @ 50° C 68,000 hours L50 @ 50° C
Electrical	Input Voltage	100 / 120 / 240 / 277 VAC, auto-switching, 50 / 60 Hz	
	Power Consumption	50 W maximum at full output, steady state	
	Power Factor	.98 @ 120 VAC	
Control	Dimming	Compatible with selected commercially available reverse-phase ELV-type dimmers§	
Physical	Dimensions (Height x Width x Depth)	7.1 x 12.5 x 4.9 in (180 x 318 x 124 mm)	
	Weight	6.4 lb (2.9 kg)	
	Housing	Die-cast aluminium, white or black powder-coated finish	
	Lens	Clear tempered glass (10° and 83° beam angles) Frosted tempered glass (21° and 36° beam angles)	
	Fixture Connections	6 ft (1.8 m) unified power / data cable	
	Temperature Ranges	-40° – 122° F (-40° – 50° C) Operating -4° – 122° F (-20° – 50° C) Startup -40° – 176° F (-40° – 80° C) Storage	
Fixture Run Lengths	To calculate fixture run lengths and total power consumption for your specific installation, download the Configuration Calculator from www.philipscolorkinetics.com/support/install_tool/		
Certification and Safety	Humidity	0 – 95%, non-condensing	
	Certification	UL / cUL, FCC Class B, CE	
	Environment	Dry / Damp / Wet Location, IP66	

* Correlated color temperature (CCT) complies with ANSI C78.377-2008 for the chromaticity of solid state lighting products.

† Lumen measurement complies with IES LM-79-08 testing procedures.

‡ L70 = 70% lumen maintenance (when light output drops below 70% of initial output). L50 = 50% lumen maintenance (when light output drops below 50% of initial output). Ambient luminaire temperatures specified. Lumen maintenance calculations are based on lifetime prediction graphs supplied by LED source manufacturers. Calculations for white-light LED fixtures are based on measurements that comply with IES LM-80-08 testing procedures. Refer to www.philipscolorkinetics.com/support/appnotes/ for more information.

§ Refer to www.philipscolorkinetics.com/support/appnotes/ for more information.

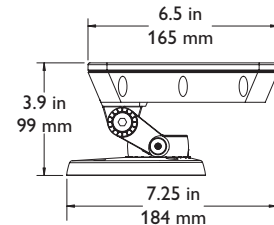
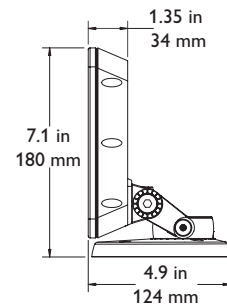
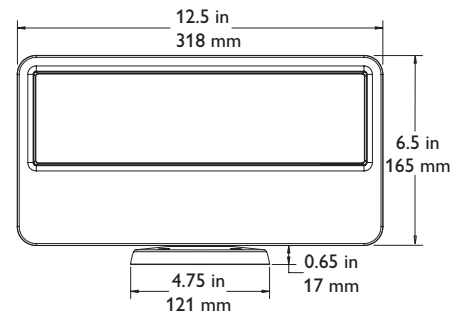
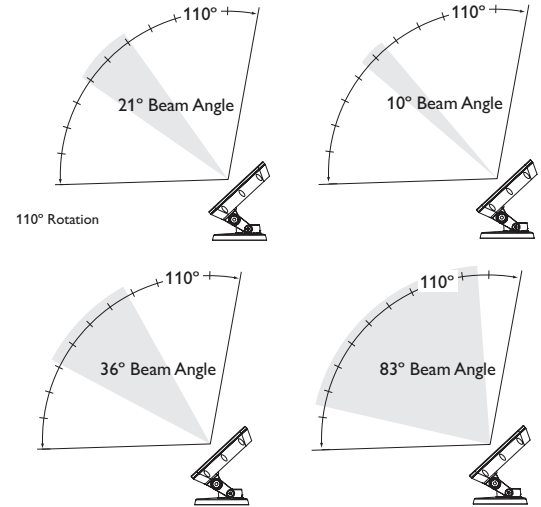

OPTIBIN[®] | POWERCORE[®] | DIMAND[®]
CK TECHNOLOGY | CK TECHNOLOGY | CK TECHNOLOGY



Fixtures

Included in the box

eW Blast Powercore fixture
(2) 8-32 screws for indoor installation
(4) 10-24 stainless steel screws for outdoor installation
1/8 in hex key wrench for fixture positioning and locking
Junction box gasket
Installation Instructions

Item	Housing Color	Lens	Item Number	Philips 12NC
eW Blast Powercore 2700 K UL / cUL	White	10° (clear lens)	523-000069-00	910503702322
		21° (frosted lens)	523-000069-02	910503702365
		36° (frosted lens)	523-000069-04	910503702367
		83° (no optic)	523-000069-06	910503702369
	Black	10° (clear lens)	523-000069-01	910503702364
		21° (frosted lens)	523-000069-03	910503702366
		36° (frosted lens)	523-000069-05	910503702368
eW Blast Powercore 4000 K UL / cUL	White	83° (no optic)	523-000069-07	910503702370
		10° (clear lens)	523-000069-08	910503702371
		21° (frosted lens)	523-000069-10	910503702373
		36° (frosted lens)	523-000069-12	910503702375
	Black	83° (no optic)	523-000069-14	910503702377
		10° (clear lens)	523-000069-09	910503702372
		21° (frosted lens)	523-000069-11	910503702374
		36° (frosted lens)	523-000069-13	910503702376
		83° (no optic)	523-000069-15	910503702378
		10° (clear lens)	523-000069-16	910503702379
eW Blast Powercore 2700 K CE / CQC	White	21° (frosted lens)	523-000069-18	910503702381
		36° (frosted lens)	523-000069-20	910503702383
		83° (no optic)	523-000069-22	910503702385
		10° (clear lens)	523-000069-17	910503702380
	Black	21° (frosted lens)	523-000069-19	910503702382
		36° (frosted lens)	523-000069-21	910503702384
		83° (no optic)	523-000069-23	910503702386
eW Blast Powercore 4000 K CE / CQC	White	10° (clear lens)	523-000069-24	910503702387
		21° (frosted lens)	523-000069-26	910503702389
		36° (frosted lens)	523-000069-28	910503702391
		83° (no optic)	523-000069-30	910503702393
	Black	10° (clear lens)	523-000069-25	910503702388
		21° (frosted lens)	523-000069-27	910503702390
		36° (frosted lens)	523-000069-29	910503702392
		83° (no optic)	523-000069-31	910503702394

Use Item Number when ordering in North America.

Accessories

Designed specifically for the family of Blast fixtures, accessories provide additional options for controlling and dispersing light. Accessory holders snap to the front of the fixture and are required for mounting accessories. Accessory holders prevent accessories from falling out if the fixture is tipped or hung upside down.

Item	Housing Color	Item Number	Philips 12NC	
Accessory Holders	White	120-000070-00	910503702864	
	Black	120-000070-01	910503702863	
Top Hats	White	120-000005-03	910503702847	
	Black	120-000005-04	910503702848	
Half Top Hats	White	120-000009-03	910503702843	
	Black	120-000009-04	910503702844	
Egg Crate Louvers	White	120-000015-03	910503702851	
	Black	120-000015-04	910503702852	
Barndoors	White	120-000019-03	910503702855	
	Black	120-000019-04	910503702856	
Horizontal Glass Spread Lens*	36° (ribs out) / 50° (ribs in)	120-000025-00	910503703897	
Horizontal / Vertical Glass Spread Lens*	40°	120-000025-01	910503703898	

* Intended for use with Blast fixtures with 10° clear lens

Use Item Number when ordering in North America.

✳️ Refer to the eW Blast Powercore Installation Instructions for specific warning and caution statements.

Included in the box

eW Blast Powercore fixture
(2) 8-32 screws for indoor installation
(4) 10-24 stainless steel screws for outdoor installation
1/8 in hex key wrench for fixture positioning and locking
Junction box gasket
Installation Instructions

Installation

eW Blast Powercore is an LED wash light providing high-intensity white light while consuming less energy than comparable non-LED fixtures. Powercore, which delivers line voltage directly to the fixture, eases installation by eliminating the need for external power supplies or special wiring.

Owner/User Responsibilities

It is the responsibility of the contractor, installer, purchaser, owner, and user to install, maintain, and operate eW Blast Powercore fixtures in such a manner as to comply with all applicable codes, state and local laws, ordinances, and regulations. Consult with the appropriate electrical inspector to ensure compliance.

Installing in Damp or Wet Locations

When installing in damp or wet locations, it is good practice to seal all fixtures and junction boxes with electronics-grade RTV silicone sealant to ensure that moisture cannot enter or accumulate in any wiring compartments, cables, or other electrical parts. You must use suitable outdoor-rated junction boxes when installing in damp or wet locations. Additionally, you must use gaskets, clamps, and other parts required for installation to comply with all applicable local and national codes.

Assemble Additional Parts and Tools

Make sure all additional parts and tools are available, including:

- The provided 8-32 screws for indoor installations, or the 10-24 stainless steel screws for outdoor installations
- The provided 1/8 in hex key wrench
- One 4 in (102 mm) round US electrical junction box per fixture, rated for your application, with 3.5 in (89 mm) center-to-center screw holes for attaching the fixture's base. (Refer to the manufacturer's literature for additional items required for mounting or sealing.)
- The provided junction box gasket
- A sufficient length of 3-conductor copper wire
- Conduit as required
- Electronics-grade room temperature vulcanizing (RTV) silicone sealant as required

Install the Fixtures

eW Blast Powercore fixtures can be installed in series or in parallel (wired to a common junction box). Each fixture requires a dedicated junction box for mounting. Ensure that all junction boxes are suitable for the environment and that all wiring between junction boxes complies with local codes.

eW Blast Powercore fixtures can be controlled either with a standard wall switch (on / off) or a commercially available reverse-phase ELV-type dimmer. Refer to the installation instructions included with the wall of dimmer switch for installing and wiring information.

Make sure the power is OFF before mounting and connecting fixtures.

1. Install junction boxes. (Refer to the manufacturer's literature for additional items required for mounting or sealing.)
2. If installing fixtures in a series, pull 3-conductor copper wire between the junction boxes. If installing fixtures in parallel, pull 3-conductor copper wire from a common junction box, and from the common junction box to each fixture's junction box.
3. Trim the cable from the fixture to fit in the junction box, leaving enough cable to make wiring connections.
4. Insert the fixture cable through the provided junction box gasket before making wire connections. When attaching the fixture to the junction box, ensure that the gasket is compressed evenly.
5. For UL / cUL installations, use wire nuts to connect line (black), neutral (white), and ground (green). For CE / CQC installations, use wire nuts to connect line (brown), neutral (blue), and ground (green / yellow).

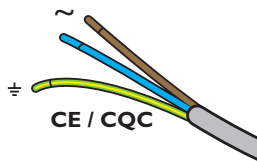
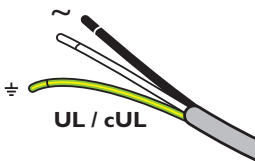

6. Tuck wire connections into the junction box, and use the provided screws to attach the fixture to the junction box.
7. If installing in a wet or damp location, seal all junction boxes with electronics-grade RTV silicone sealant. Use gaskets, clamps, and other parts and fittings required to comply with local outdoor wiring codes.
8. If installing in parallel, connect the wires from each fixture to the lead wire from the line power source in the common junction box.
9. Connect the wire from the first fixture in the series to the line power source if installing in series, or from the common junction box to the line power source if installing in parallel.

* In locations where US junction boxes are not available, you can mount fixtures directly to a wall or other mounting surface. For help with your specific installation, consult your local support organization, or contact Application Engineering Services at support@colorkinetics.com.

* When installing eW Blast Powercore fixtures, the input earth ground, canopy earth ground, and fixture cable earth ground must all be connected together.

Fixture cable dimensions

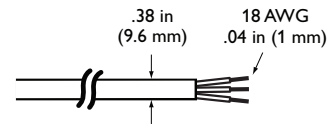

* Wiring between junction boxes must comply with local codes.

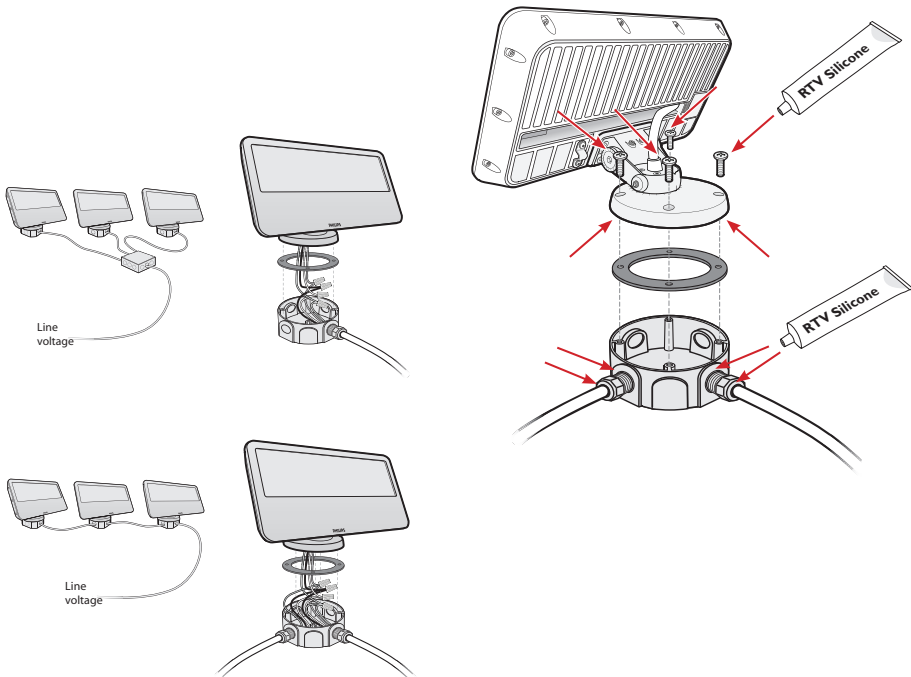

Attach Safety Cable (Optional)

Each eW Blast Powercore fixture is designed for use with a safety cable to tether the fixture to a secure anchor point. When dictated by local or state code or advised by a structural engineer, attach a safety cable to the bracket located on the back of the fixture. Remove the two screws that attach the cable bracket, loop the safety cable over the cable bracket, and reattach to the fixture. Attach the safety cable to the mounting surface using a method that follows the code or engineer's requirements.

Safety cable minimum requirements

Material	316 Stainless Steel
Size	5/64 to 3/16 in (2.0 to 4.8 mm) nominal diameter. Minimum break load must be greater than 400 lb (181 kg)
Construction	7 x 7 (49 wires) preformed stranded

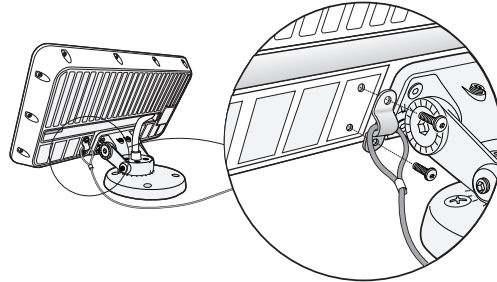

✳ Do not look directly into the fixture when aiming and locking.

✳ For exterior applications with direct exposure to water, eW Blast Powercore fixtures should not be aimed directly upwards, as water may pool on the lens and affect beam quality. Instead, the fixture should be angled to allow for proper water drainage.

Aim and Lock the Fixtures

Make sure the power is ON before aiming and locking the fixtures.

Using the provided 1/8 in hex key wrench, loosen the rotation and tilting set screws. Aim the fixtures by rotating the base and tilting the beam as desired. Tighten the two pairs of set screws to lock the fixture in place.

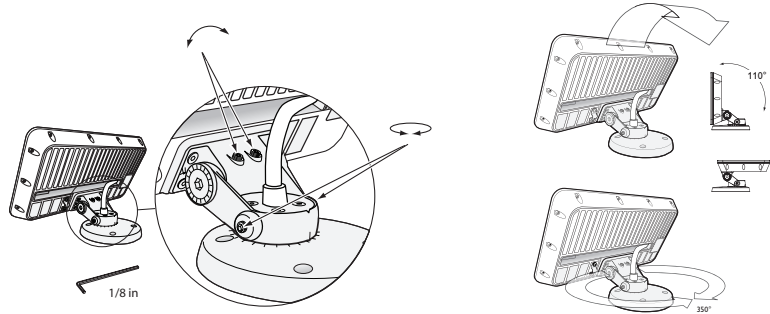
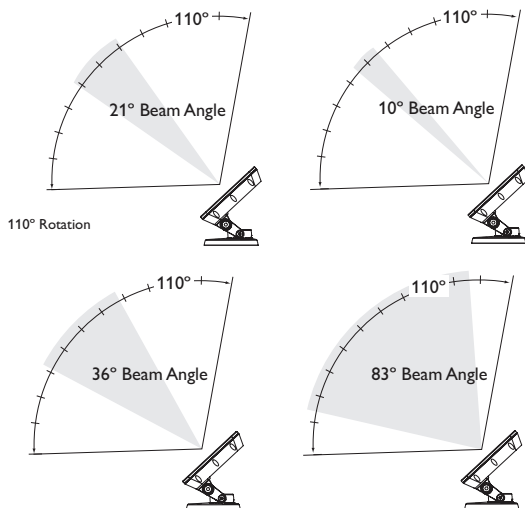



Philips Color Kinetics
3 Burlington Woods Drive
Burlington, Massachusetts 01803 USA
Tel 888.385.5742
Tel 617.423.9999
Fax 617.423.9998
www.philipscolorkinetics.com

Copyright © 2008 – 2012 Philips Solid-State Lighting Solutions, Inc. All rights reserved.
Chromacore, Chromasic, CK, the CK logo, Color Kinetics, the Color Kinetics logo, ColorBlast,
ColorBlaze, ColorBurst, eW Fuse, ColorGraze, ColorPlay, ColorReach, iW Reach, eW Reach,
DIMand, EssentialWhite, eW, iColor, iColor Cove, IntelliWhite, iW, iPlayer, Optibin, and Powercore
are either registered trademarks or trademarks of Philips Solid-State Lighting Solutions, Inc. in
the United States and / or other countries. All other brand or product names are trademarks
or registered trademarks of their respective owners. Due to continuous improvements and
innovations, specifications may change without notice.
Cover Photo: John Brandon Miller Photography

DAS-000024-00 R09 08-12