

LED Solar Wall Pack



A Simple & Fast Installation!

Keep your business premises safe with powerful modern solar wall lights that maintain high visibility whenever people approach the grounds and building. With multiple settings, a long lifetime, and low maintenance, modern solar wall lights are the ideal addition to your business security.

Features

- Solar Wall Pack with Motion Sensor
- User replaceable lithium battery
- On/Off motion sensor
- Quick and easy installation
- Certifications / Listed: IP65
- Watts: 5W
- Initial Lumens: 450-500 LM
- Life (L70): 50,000
- Color Temp: 5000K



LED Solar Wall Packs Quick Search Code: S21506



Product No	Description	Equivalency
SL-PSWP5LED5-50	5W 450-500LM 5000K	90-100 MH



Dimensions

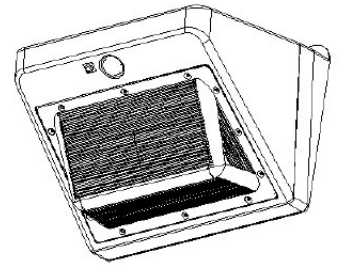
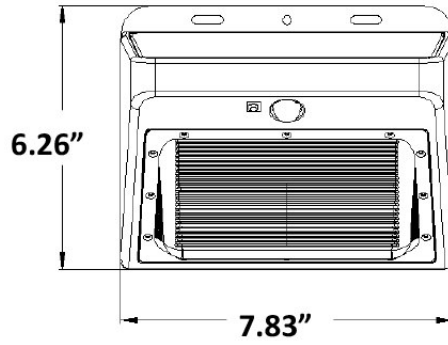
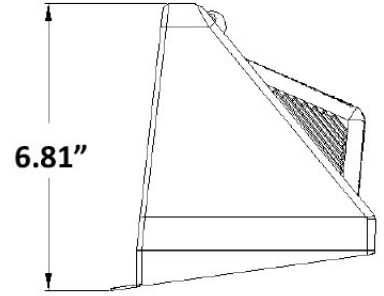
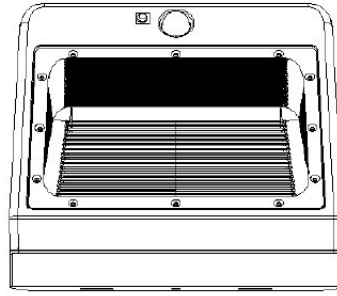

Application

