

LED 26 Watt Mini Wall Pack - Color Selectable 3K/4K/5K

Search Code: SC7040



FEATURES

- 3CCT selectable (3000K/4000K/5000K)
- 3,500 lumens, Replaces 150W
- Die-cast aluminum housing, bronze finish
- High-transmittance optical lens, 120° beam angle
- Built-in photocell, 0–10V dimming
- 50,000-hour rated life (DLC Premium)

ELECTRICAL

- Wattage: 26W
- Input Voltage: 120–277V AC
- Lumens: 3,500lm
- CRI: 80
- Beam Angle: 120°
- Operating Temp: -20°C to +45°C
- Driver: UKH UL Driver

APPLICATION

- Warehouses & factories
- Supermarkets & shopping plazas
- Logistics centers
- Auto dealerships
- Stadiums & sports facilities
- Parking lot perimeters



Front View



Side View

WARRANTY & LISTINGS

- 5-year limited warranty
- UL / cUL Listed
- DLC Premium Listed

DIMENSIONS

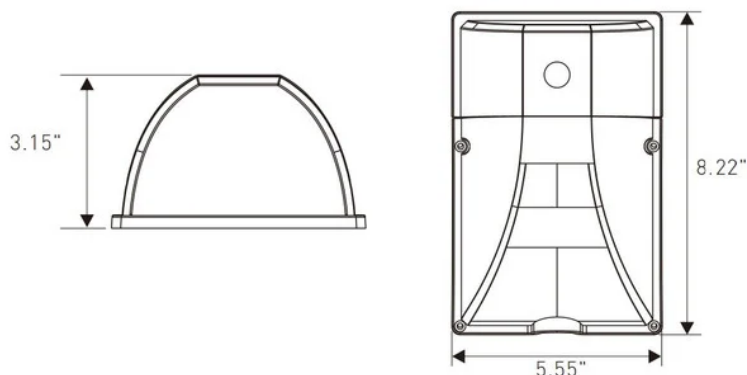

ORDERING INFORMATION

Product Code	Wattage	Replaces	Lumens	Color Temperature
WM25W27V50KDP2	26W	150W	3500L	Color Selectable 3000K /4000K /5000K

B.U.G RATING

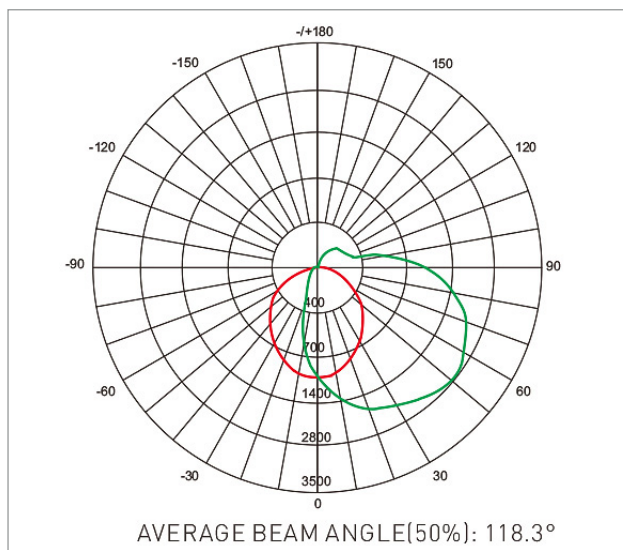

Installation Instructions

Cautions:

1. Can not use the electric generator to test the LED lamp.
2. Please abide by related country, regional and local law and regulations when install this fixture.
3. Please turn off the power before installation or maintenance.
4. Proper earth grounding is required to ensure safety.

Notice:

1. To avoid possibility of electrical shock or fire, the installation personnel must have professional electric knowledge.
2. Please wear gloves to avoid injury before installation.
3. If any smoke or spark of the wire happened, please turn off the power immediately and notify relevant personnel.

Attention:

1. Please check if there is any damage during shipping. If so, please contact manufacturer timely.
2. Please read the installation instruction carefully to check whether all the accessories are complete. After confirmation, then install the fixture according to installation steps.

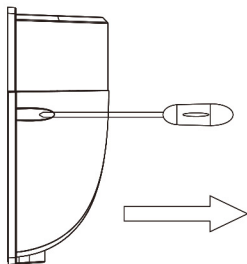

1. Remove the cover screw

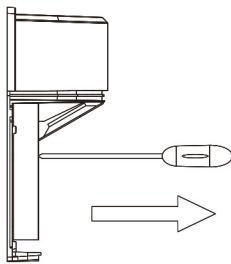

2. Then remove the wire cover screw

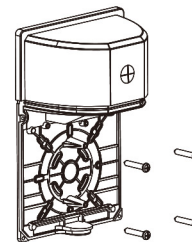

3. Punches according to wall position
And in the screw position waterproof
glue

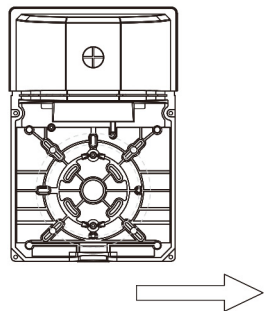

4. Fix the shell to the wall

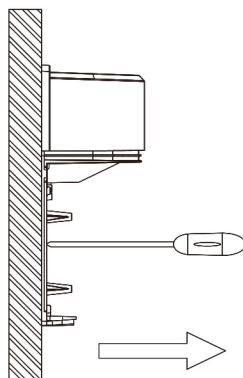

5. Cover screw twisted

